

V274E Technical Data Sheet

INSULATION SYSTEM	CLASS H	CONTROL SYSTEM	SELF EXCITED
PROTECTION	IP23	A.V.R.	AS440
WINDING PITCH	2/3	VOLTAGE REGULATION	±1.0 %
WINDING LEADS	12	SUSTAINED SHORT CIRCUIT	NOT
MAXIMUM / OVERSPEED	2250 Rev/Min	WAVEFORM DISTORTION	NO LOAD < 1.5% NON-DISTORTING BALANCED LINEAR LOAD < 5.0%
		TELEPHONE INTERFERENCE: THF	THF < 2%
		TELEPHONE INTERFERENCE: TIF	TIF < 50

50Hz CLASS "H"

RATINGS		Winding 311 / 0.8 Power Factor								
Duty/Ambient T°. RISE		Cont.125K/40°C			Standby - 150/40°			Cont.125K/40°C		
PHASE		3 PHASE						1 PHASE		
SERIES STAR		380	400	415	380	400	415			
PARALLEL STAR		190	200	208	190	200	208			
SERIES DELTA		220	230	240	220	230	240			
DOUBLE DELTA								220	230	240
SLG274E	KVA	140	140	140	145	145	145	85	85	85
	KW	112	112	112	116	116	116	68	68	68

60Hz CLASS "H"

RATINGS		Winding 311 / 0.8 Power Factor										
Duty/Ambient T°. RISE		Cont.125K/40°C			Standby - 150/40°			Cont.125K/40°C				
PHASE		3 PHASE						1 PHASE				
SERIES STAR		416	440	460	480	416	440	460	480			
PARALLEL STAR		208	220	230	240	208	220	230	240			
SERIES DELTA		240	254	266	277	240	254	266	277			
DOUBLE DELTA										220	230	240
SLG274E	KVA	160	167.5	167.5	178.8	170	175	175	187.5	84	90	96
	KW	128	134	134	143	136	140	140	150	67.2	72	76.8

REACTANCES , TIME CONSTANTS (s) : CLASS : H / 400 V

	SLG274E	
	50Hz/400V	60Hz/440V
Xd DIR. AXIS SYNCHRONOUS	2.11	2.51
X'd DIR. AXIS TRANSIENT	0.19	0.23
X''d DIR. AXIS SUBTRANSIENT	0.13	0.16
Xq QUAD. AXIS REACTANCE	1.38	1.63
X''q QUAD. AXIS SUBTRANSIENT	0.16	0.21
XL LEAKAGE REACTANCE	0.08	0.08
X2 NEGATIVE SEQUENCE	0.14	0.18
X0 ZERO SEQUENCE	0.09	0.10
T'd TRANSIENT TIME CONST. (s)	0.032	
T''d SUB-TRANSTIME CONST. (s)	0.01	
T'do O.C. FIELD TIME CONST. (s)	0.85	
Ta ARMATURE TIME CONST. (s)	0.007	
SHORT CIRCUIT RATIO	1/ Xd	

50Hz 400V Winding 311 THREE PHASE EFFICIENCY CURVES

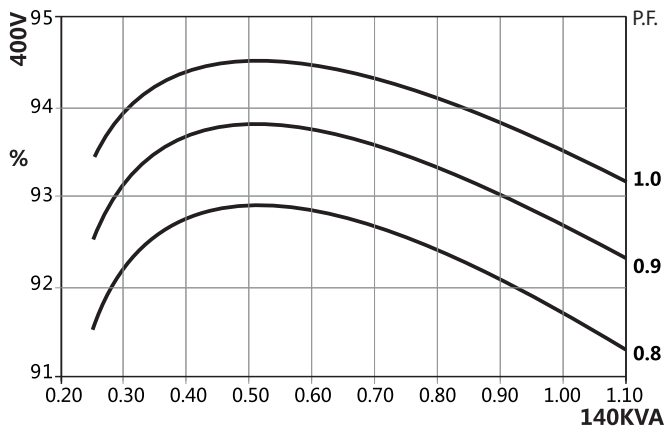

60Hz 440V Winding 311 THREE PHASE EFFICIENCY CURVES

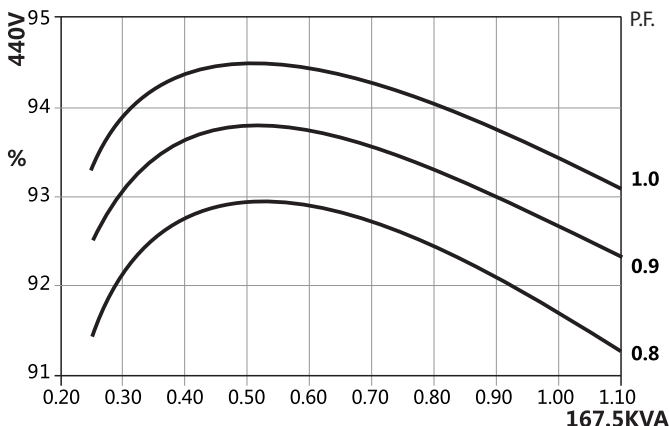

50Hz 400V Winding 311 Locked Rotor Motor Starting Curve

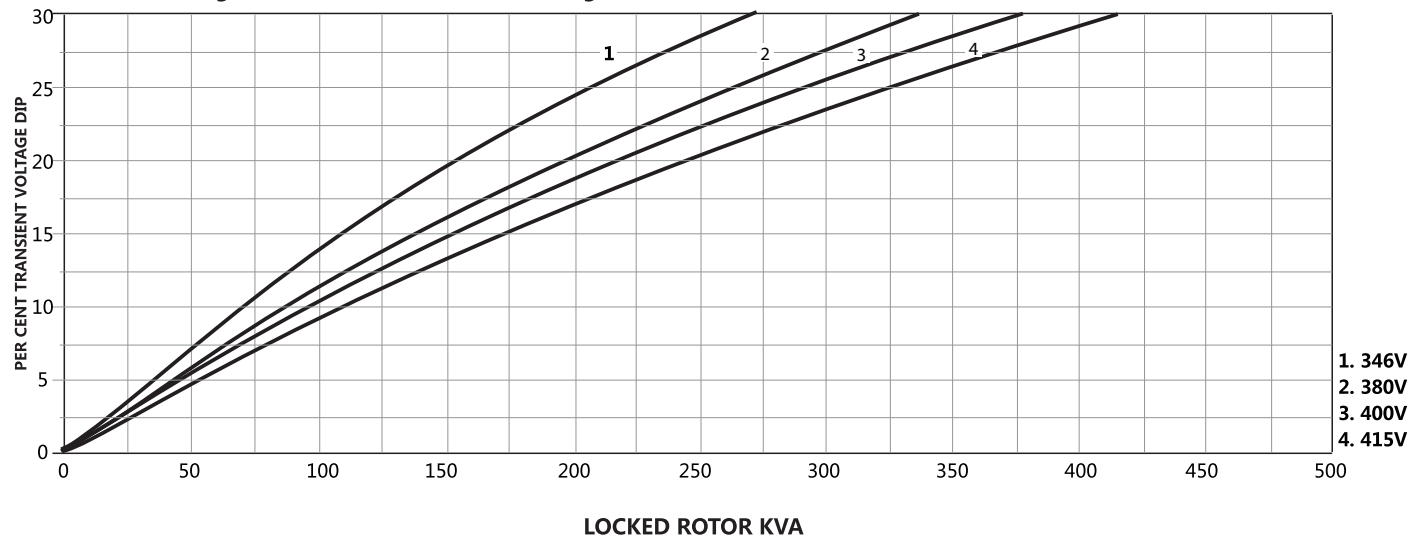

Single bearing external dimension

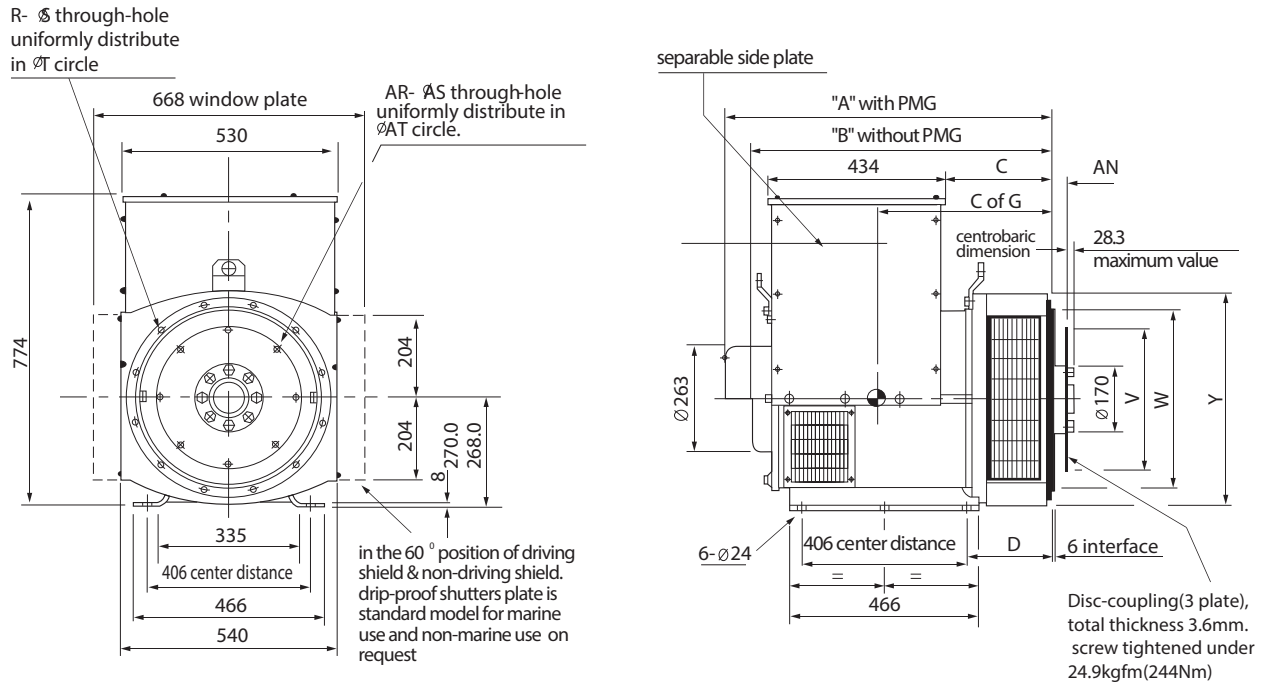

DIMENSION (mm)						
	Model	A	B	C	E	Cof G
SAE1	SLG274E	928.3	865.3	389.3	560	390
SAE2&3	SLG274E	914	851	375	540	489

DISC COUPLING (mm)						
S.A.E.NO.	AN	AR	AS	AT	V	
10	53.98	8	10.3	295.3	314.2	
11.5	39.68	8	10.3	333.3	352.3	
14	25.40	8	13.5	438.2	466.6	

FLANGE (mm)						
S.A.E.NO.	D	R	S	T	W	Y
1	216.3	12	12.7	530.2	511.1	580
2	202	12	11	466.7	447.6	530
3	202	12	11	428.6	409.5	530

SAE NO SELECTOR CHOWT			
	SAE10	SAE11.5	SAE14
SAE 1		•	•
SAE 2		•	
SAE 3	•	•	

TRANSPORTATION DATA				
Model	N.W(kg)	G.W(kg)	LXWXH(cm)	QTY FOR 20FT CONTAINER
SLG274E	455	485	106x69x97	32

Double bearing external dimension

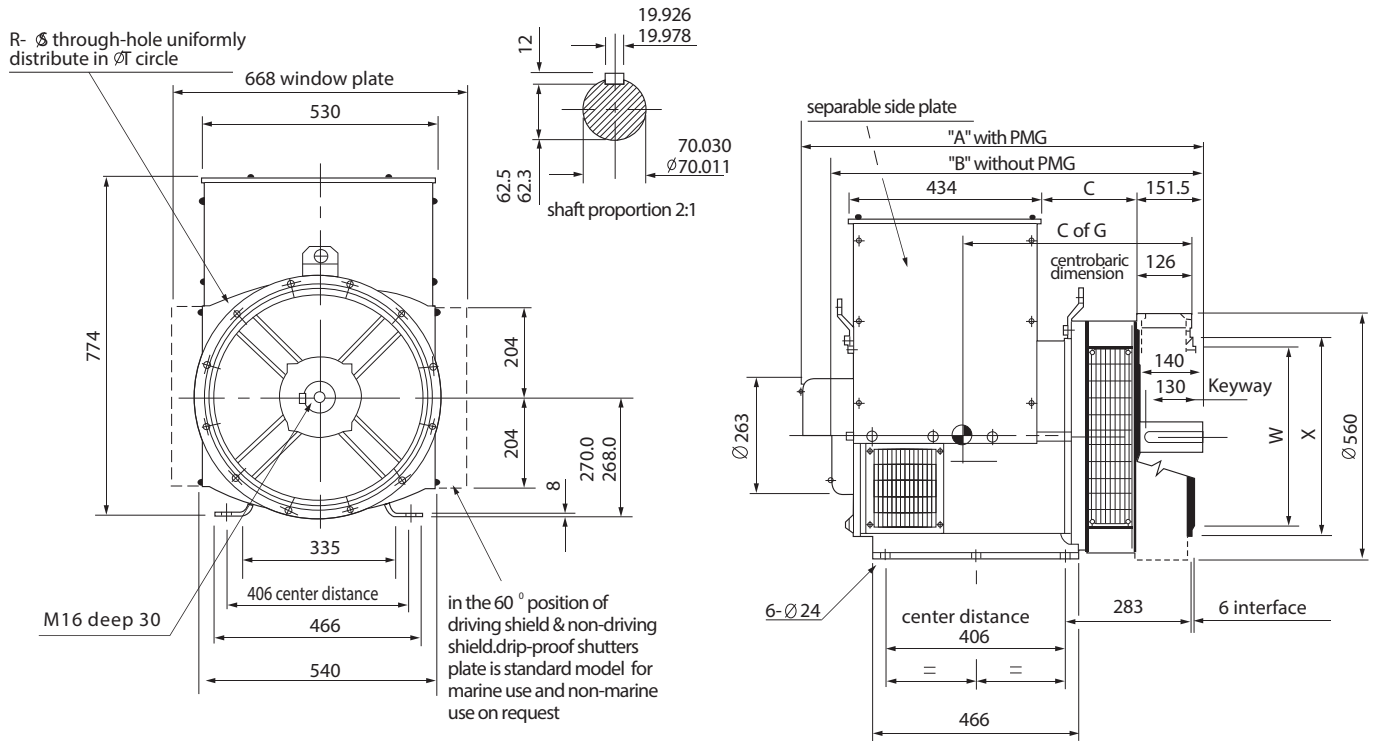

DIMENSION

Model	A	B	C	C of G
SLG274E	1020	957	330	445

FLANGE (mm)

S.A.E.NO.	R	S	T	W	X
1	12	12.7	530.2	511.1	553
2	12	11	466.7	447.6	495
3	12	11	428.6	409.5	451

TRANSPORTATION DATA

Model	N.W(kg)	G.W(kg)	LXWXH(cm)	QTY FOR 20FT CONTAINER
SLG274E	470	510	112x69x97	32